



A name you can trust

GRASS MOWERS

FOR VINEYARDS AND ORCHARDS



BERTI

A NAME YOU CAN TRUST

We are people who believe in our founders' dream of bringing agricultural and industrial machinery to all those in Italy and around the world who want to face the challenges of the job professionally.

Our mission is to produce durable, reliable and top quality equipment, minimising the risk of breakage.

Our priority is to offer solutions that make work easier and enable professionals to carry out their tasks efficiently and productively.

With our range of equipment and our commitment to customer service, we want to be the ideal partner for workers in all sectors and contribute to their daily success.

We are a Family that, with Collaboration and Trust, produces hundreds of pieces of equipment every day.

We have strong Ethics that require us to follow the highest quality standards and the Responsibility to provide every customer with the right equipment for their needs.

We look to the future with Confidence and Energy, to never stop being at your side in your daily work.





INDEX

EUROSTAR

pag. **6**

B-FLEX

pag. **12**

AV

pag. **18**

VARIANT

pag. **22**

ADDITIONAL APPLICATIONS

pag. **32**

TECHNICAL DATA

pag. **33**



EUROSTAR

GRASS MOWER FOR VINEYARDS AND ORCHARDS



160-240 cm



60-120 HP



EUROSTAR is the new Berti high-performance grassmower designed for efficient cutting of grass between rows. This machine is specifically designed for those who have vineyards and orchards with uniform row widths.



RANGE OVERVIEW

EUROSTAR is built to promote comfort and versatility. It is characterized by a robust steel frame with a linear and attractive design. The transmission is entrusted to a pair of gearboxes arranged in line that guarantee a high rotation speed of the blades and a reduction in consumption. The greasing points have been reduced to facilitate rapid maintenance. The adjustment of the cutting height is entrusted to a pair of front wheels and a rear leveling roller.

TRACTOR COUPLING

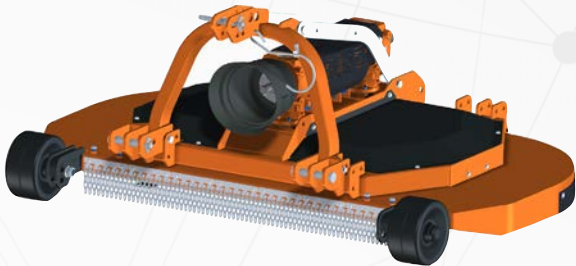

REAR THREE-POINT LINKAGE
FIXED OR DISPLACEABLE



FIXED FRONT THREE-POINT LINKAGE



FRONT & REAR THREE-POINT LINKAGE
FIXED OR DISPLACEABLE

ARRANGEMENT AND ROTATION OF CUTTING BLADES

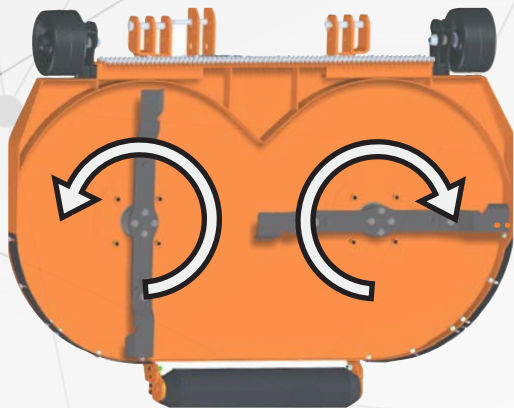

NEW HIGH VENTILATION KNIFE

EUROSTAR, THE DETAILS THAT MAKE THE DIFFERENCE

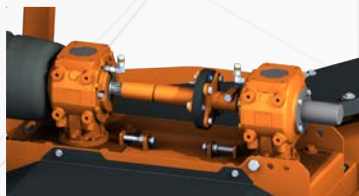

DOUBLE GEARBOX

The use of double gearbox allows the mower to reduce consumption and limits noise.

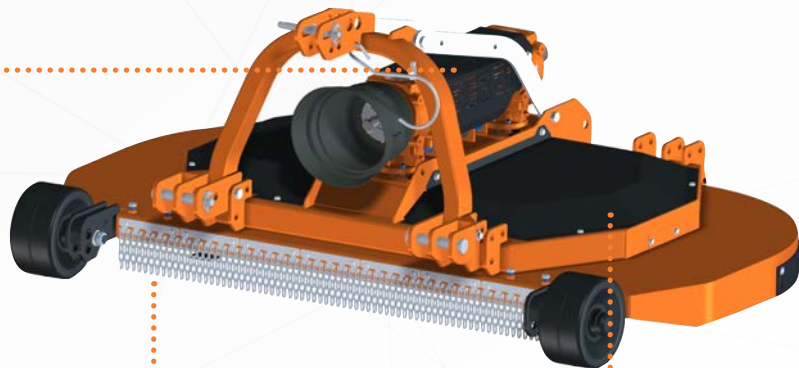

HIGH-POWER TOOTHED BELT DRIVE

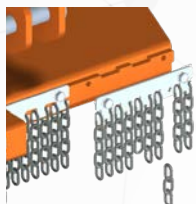

PROTECTIONS WITH "EASYFIX" CHAINS

This type of front guard allows the replacement of a single faulty chain without having to dismantle all the others.



RUBBER FLEX COUPLING

Reduces torque peaks by protecting gearboxes

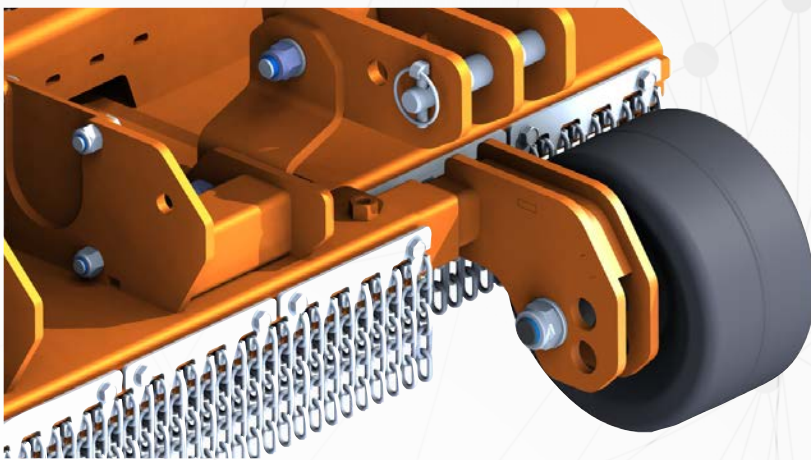
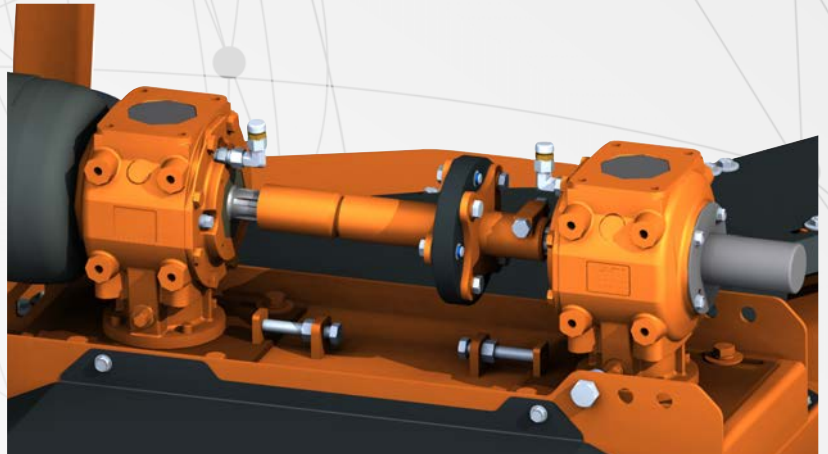

HEIGHT-ADJUSTABLE WHEELS WITH TELESCOPIC MOUNTING

Possibility of widening the wheel position by simply removing the support.

DOUBLE TIE ROD

It ensures better weight distribution during transport and manoeuvring.

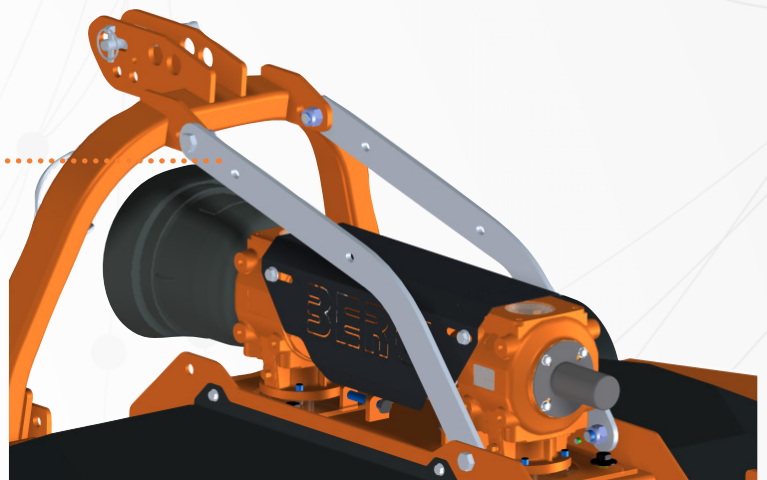

WHEELS AND ROLLER

FRONT METAL-TYPE WHEELS (standard)

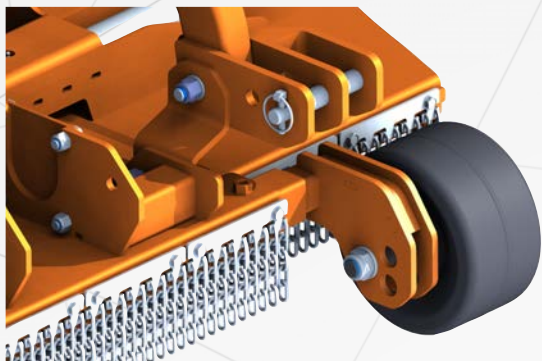

REAR ROLLER (standard)

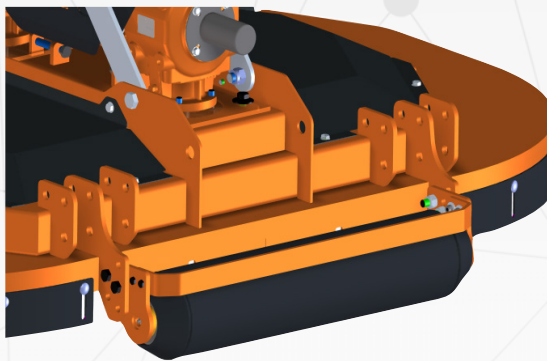

FRONT RUBBER-TYPE WHEELS (optional)

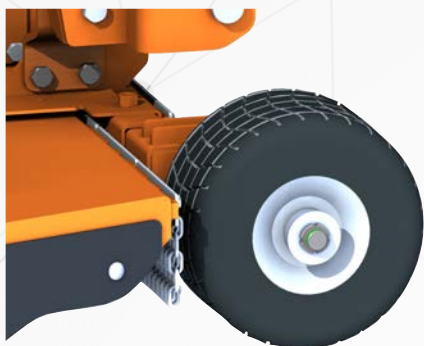

REAR MOUNT RUBBER WHEELS (optional)

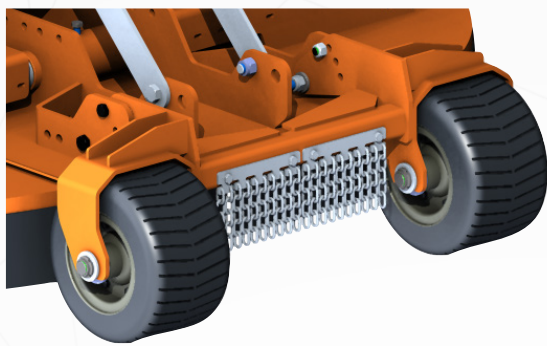

360° PIVOTING FRONT WHEELS (optional)



REAR MOUNT 360° PIVOTING FRONT WHEELS (optional)





B-FLEX

GRASS MOWER FOR VINEYARDS AND ORCHARDS



120-300 cm



60-120 HP

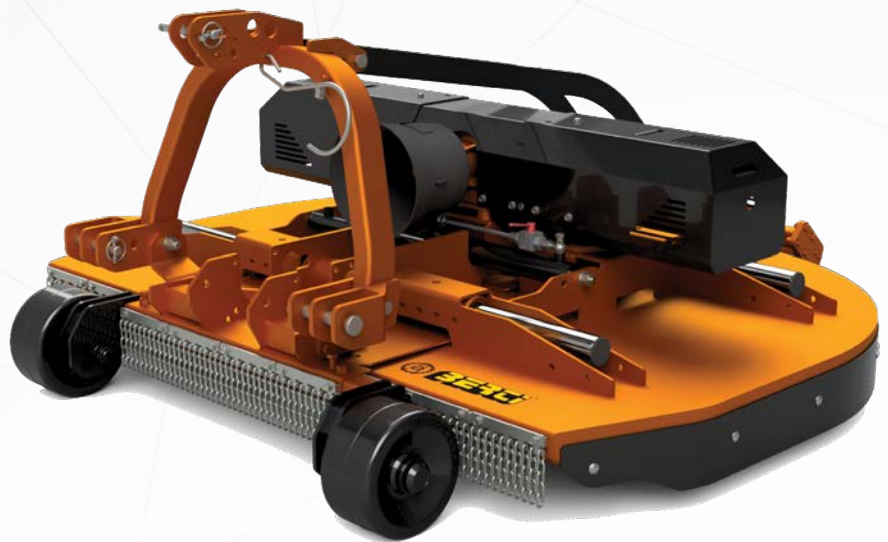

The B-FLEX grass mower is the excellent choice for the care and maintenance of vineyards and orchards, standing out for its versatility and ability to adapt to systems with variable row widths. Designed to ensure precise and effective grass cutting, B-FLEX is particularly suitable for those who need a flexible solution for plantings with non-uniform configurations.



RANGE OVERVIEW

B-Flex is characterized by a robust steel frame of innovative design, the transmission is entrusted to three gearboxes arranged in line, that guarantee maximum power transmission. The greasing points have been reduced to facilitate rapid maintenance, the cutting height adjustment is entrusted to a pair of front wheels and a rear leveling roller. The main frame is characterized by a self-cleaning system of the mowed material thanks to an inverted chassis' overlap.

TRACTOR COUPLING

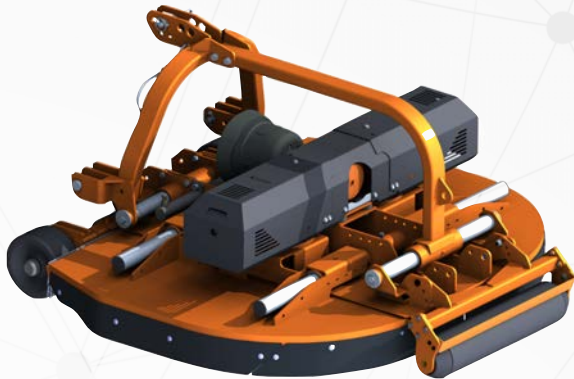

REAR THREE-POINT LINKAGE
FIXED OR DISPLACEABLE

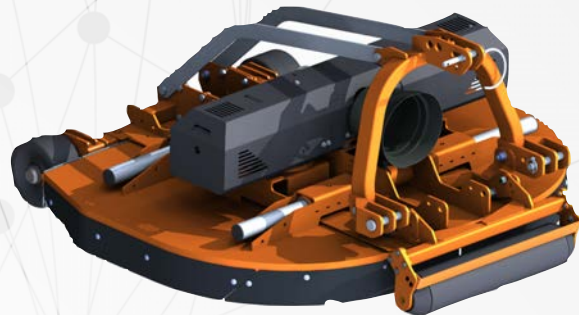

FIXED FRONT MOUNT THREE-POINT LINKAGE

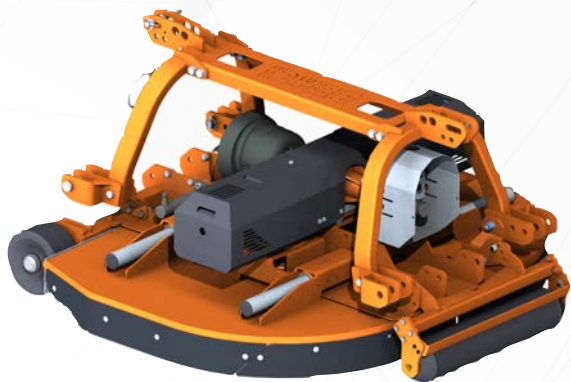

FIXED FRONT & REAR THREE-POINT LINKAGE

ARRANGEMENT AND ROTATION OF CUTTING BLADES

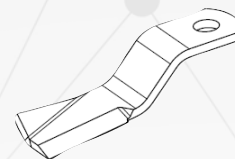
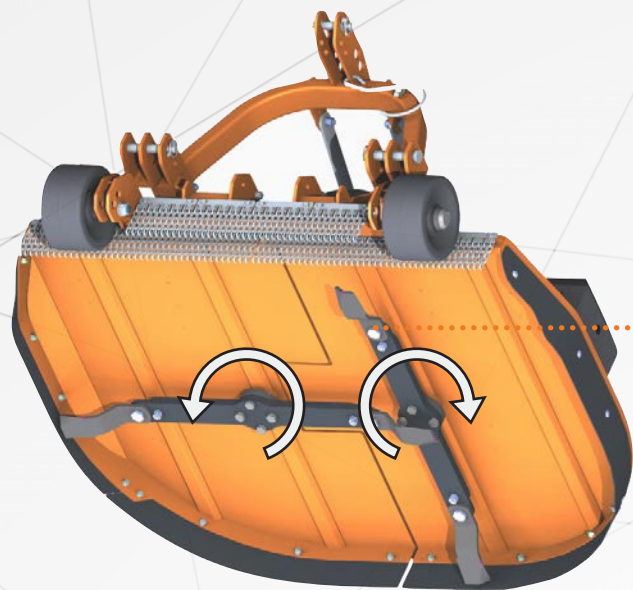

NEW HIGH VENTILATION KNIFE

B-FLEX, THE DETAILS THAT MAKE THE DIFFERENCE

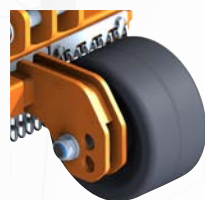
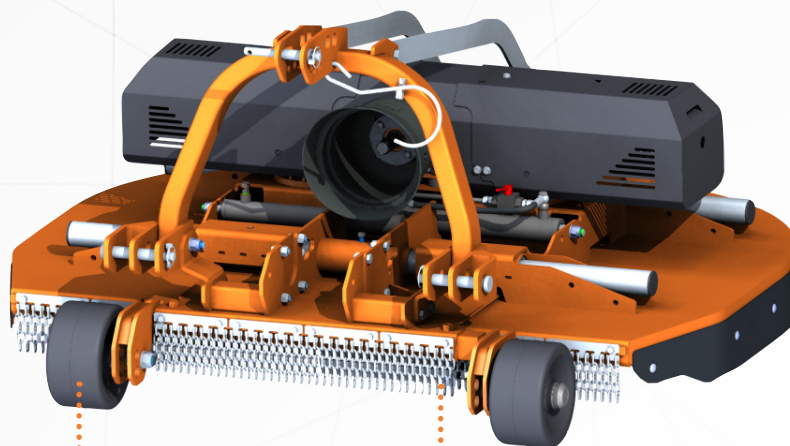

HEIGHT-ADJUSTABLE
WHEELS WITH TELESCOPIC
MOUNTING

Possibility of widening the wheel position
by simply removing the support.

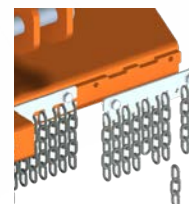

PROTECTIONS WITH "EASYFIX"
CHAINS

This type of front guard allows the
replacement of a single faulty chain
without having to dismantle all the others.



CHROMED TUBES

The opening and closing of the frame is done on chrome-plated stems

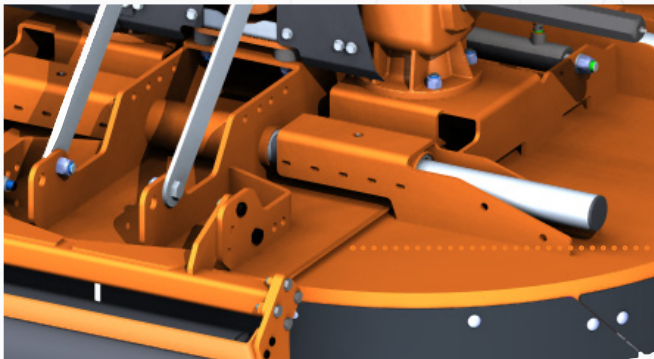
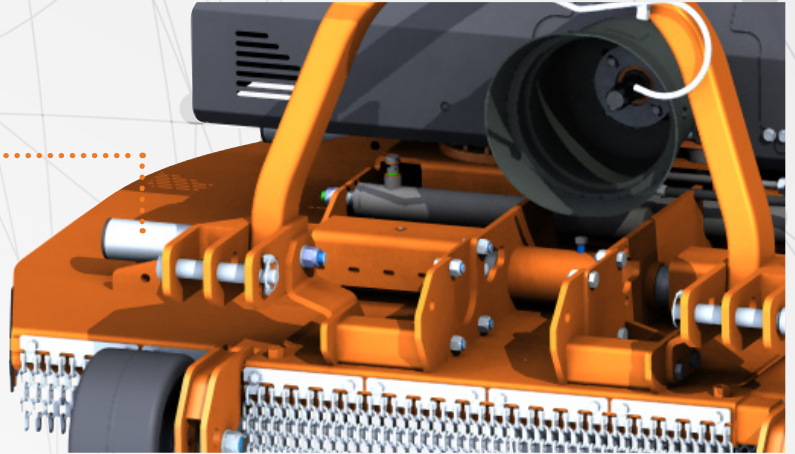

INVERTED OVERLAP (CHASSIS)

The inverted overlap allows the frame to be cleaned of the mulched material that is usually placed on top of the frame.

DOUBLE TIE ROD

It ensures better weight distribution during transport and manoeuvring.

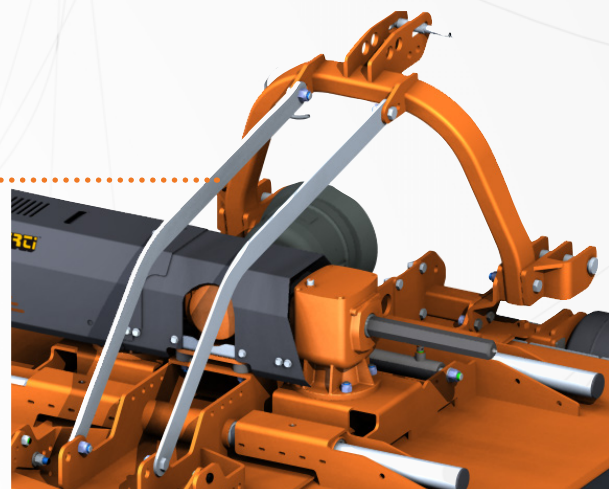

HEXAGONAL SHAFT

The use of the hexagonal shaft gives greater efficiency while ensuring maximum reliability.

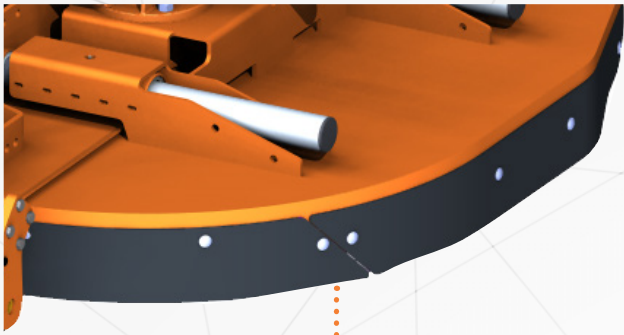
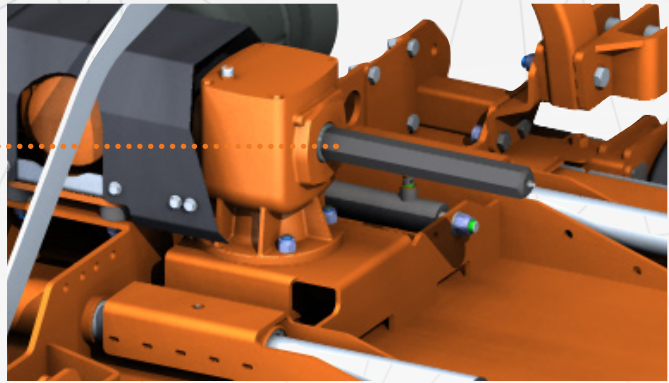

ROUNDED SHAPE DESIGN

Rounded profiles ensure greater manoeuvrability when manoeuvring.

ADJUSTABLE WORKING WIDTH

The working width is conveniently variable by simple hydraulic control, thus providing maximum flexibility of use

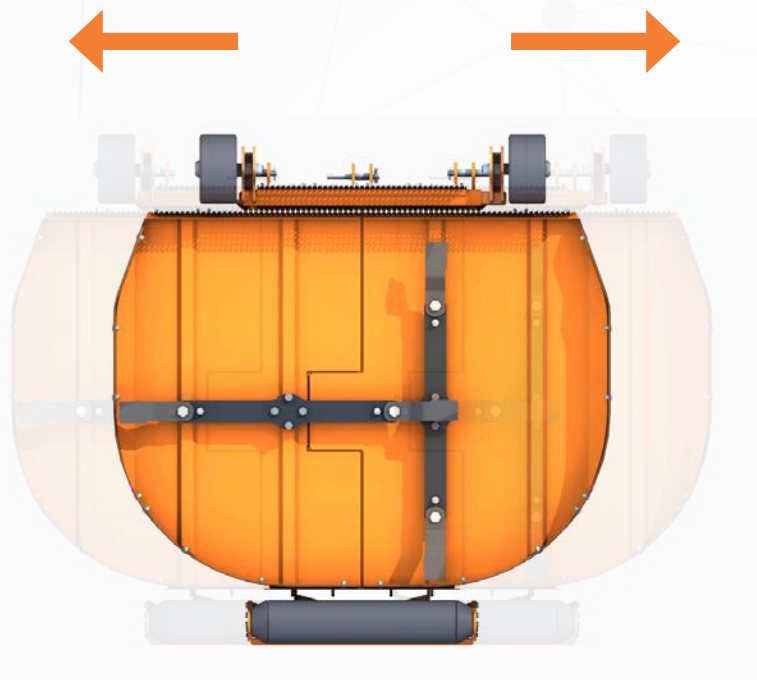

WHEELS AND ROLLER

FRONT METAL-TYPE WHEELS (standard)

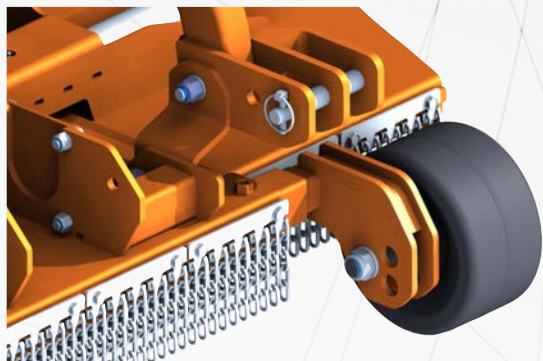

REAR ROLLER (standard)

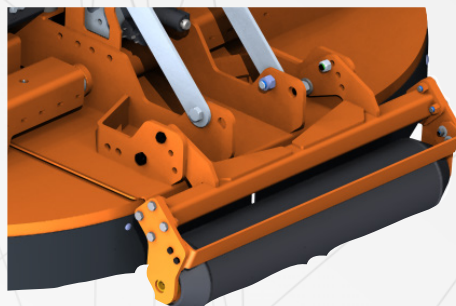

FRONT RUBBER-TYPE WHEELS (optional)

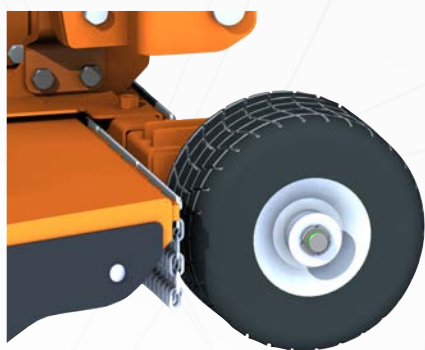

REAR MOUNT RUBBER WHEELS (optional)

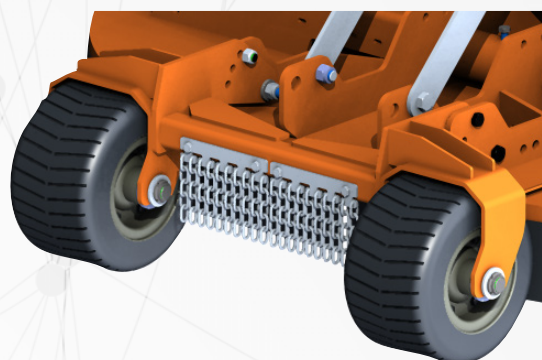

360° PIVOTING FRONT WHEELS (optional)



REAR MOUNT 360° PIVOTING FRONT WHEELS (optional)

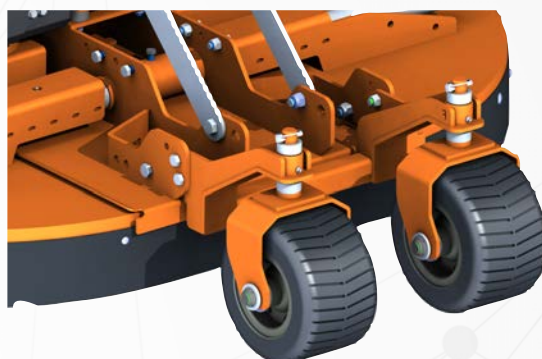

AV

GRASS MOWER FOR VINEYARD, ORCHARDS AND PHOTOVOLTAIC SYSTEMS



180-375 cm



60-120 HP



The AV grass mower is the ideal solution for managing grass in vineyards, orchards with large foliage and photovoltaic systems. Thanks to its capability of wide side-reach, it allows the operator to work comfortably in the center of the row.



RANGE OVERVIEW

The innovative design of AV is enriched by a disc that allows delicate and targeted operations not only in vineyards and orchards, but also in photovoltaic installations. The retractable disc allows inter-row work. AV stands out for its ability to combine precision, comfort and flexibility, making it an indispensable tool for those looking for professional solutions for the maintenance of large green surfaces.

TRACTOR COUPLING



REAR THREE-POINT LINKAGE
DISPLACEABLE



FRONT THREE-POINT LINKAGE
DISPLACEABLE



FRONT & REAR THREE-POINT LINKAGE
DISPLACEABLE

ARRANGEMENT AND ROTATION OF CUTTING BLADES

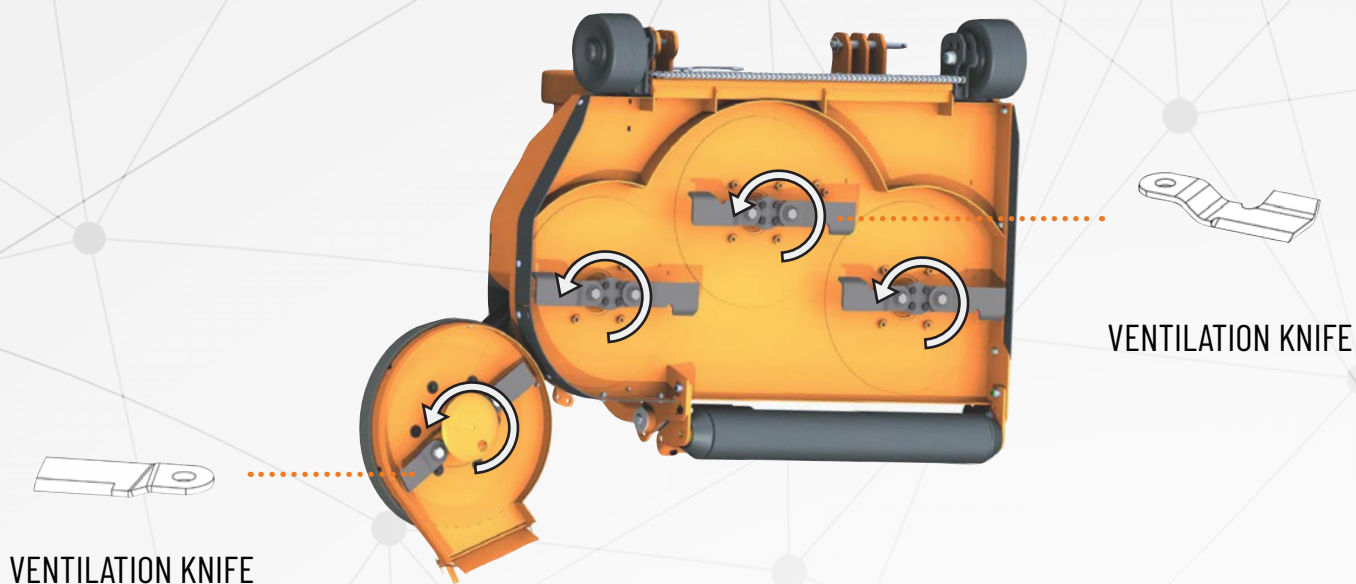

VENTILATION KNIFE

VENTILATION KNIFE

AV, THE DETAILS THAT MAKE THE DIFFERENCE



DISC WITH FREE ROTATION OF THE DECK,
HIGH RESISTANCE RUBBER PROTECTION
AND HYDRAULIC POSITIONING.

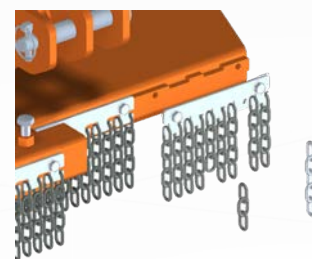

PROTECTIONS WITH "EASYFIX"
CHAINS

This type of front guard allows the replacement of a single faulty chain without having to dismantle all the others.

CHROMED TUBES

Lateral displacement takes place on chrome-plated tubes.

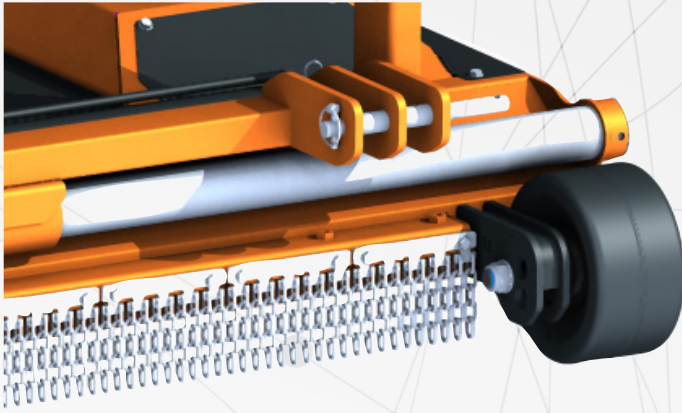

HEIGHT-ADJUSTABLE WHEELS WITH TELESCOPIC MOUNTING

Possibility of widening the wheel position
by simply removing the support.

RUBBER FLEX COUPLING

Reduces torque peaks

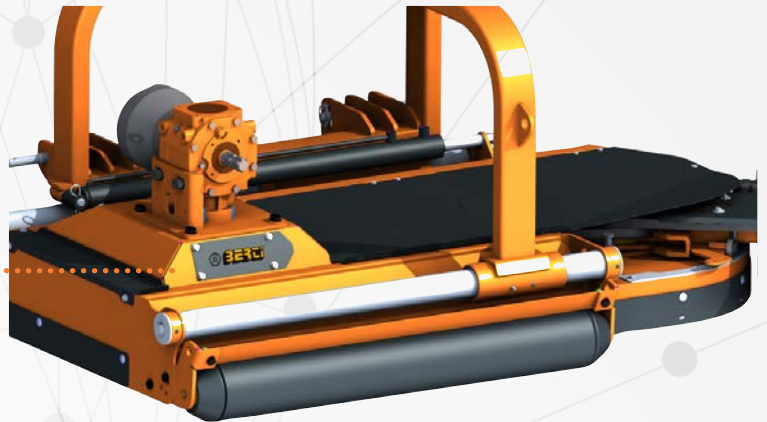

ELECTRO-HYDRAULIC FEELER

The AV electro-hydraulic feeler allows inter-row chopping on the row. This function allows complete processing with a single pass, optimizing times and reducing costs.

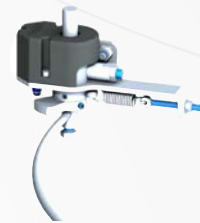
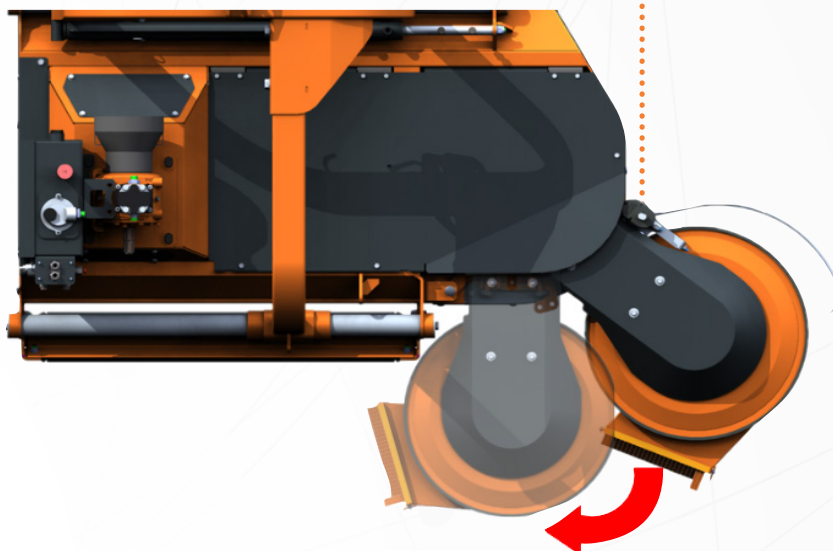

ELECTRO-HYDRAULIC FEELER

Sensitive, precise and fast.

VARIANT

GRASS MOWER FOR VINEYARDS AND ORCHARDS



160-400 cm



60-120 HP



The VARIANT grass mower is the ideal solution for mowing grass in vineyards and orchards with variable widths, thanks to its ability to adapt to systems of different sizes. Equipped with two independent adjustable discs on the sides, VARIANT is able to cover even the widest rows, ensuring a precise and uniform cut over the entire surface.



RANGE OVERVIEW

Variant is characterized by a sturdy steel frame with a linear and attractive design, the transmission is entrusted to a pair of gearboxes arranged in line that guarantee a high rotation of the blades and a reduction in consumption. The two hydraulically adjustable side discs allow the machine to easily adapt to different planting distances. The greasing points have been reduced to facilitate rapid maintenance, the cutting height adjustment is entrusted to a pair of front wheels and a rear leveling roller.

TRACTOR COUPLING



FIXED REAR THREE-POINT LINKAGE

ARRANGEMENT AND ROTATION OF CUTTING BLADES

NEW HIGH VENTILATION KNIFE

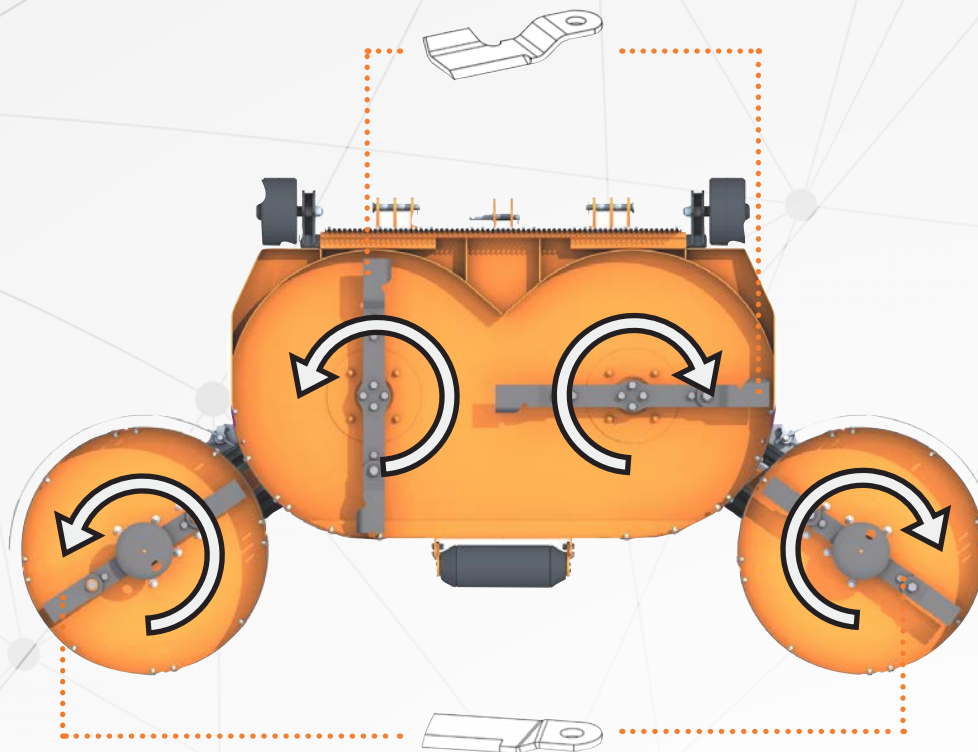

VENTILATION KNIFE

VARIANT, THE DETAILS THAT MAKE THE DIFFERENCE

PROTECTIONS WITH "EASYFIX" CHAINS

This type of front guard allows the replacement of a single faulty chain without having to dismantle all the others.

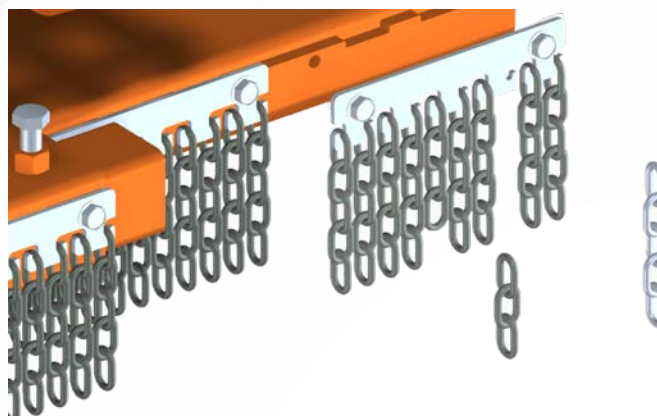

HEIGHT-ADJUSTABLE WHEELS WITH TELESCOPIC MOUNTING

Possibility of widening the wheel position
by simply removing the support.

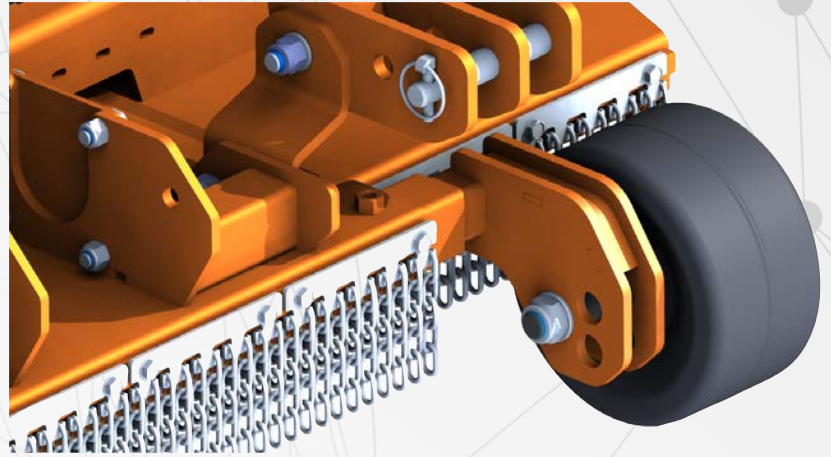

PRIMARY TRANSMISSION

Consisting of gearbox and toothed belts

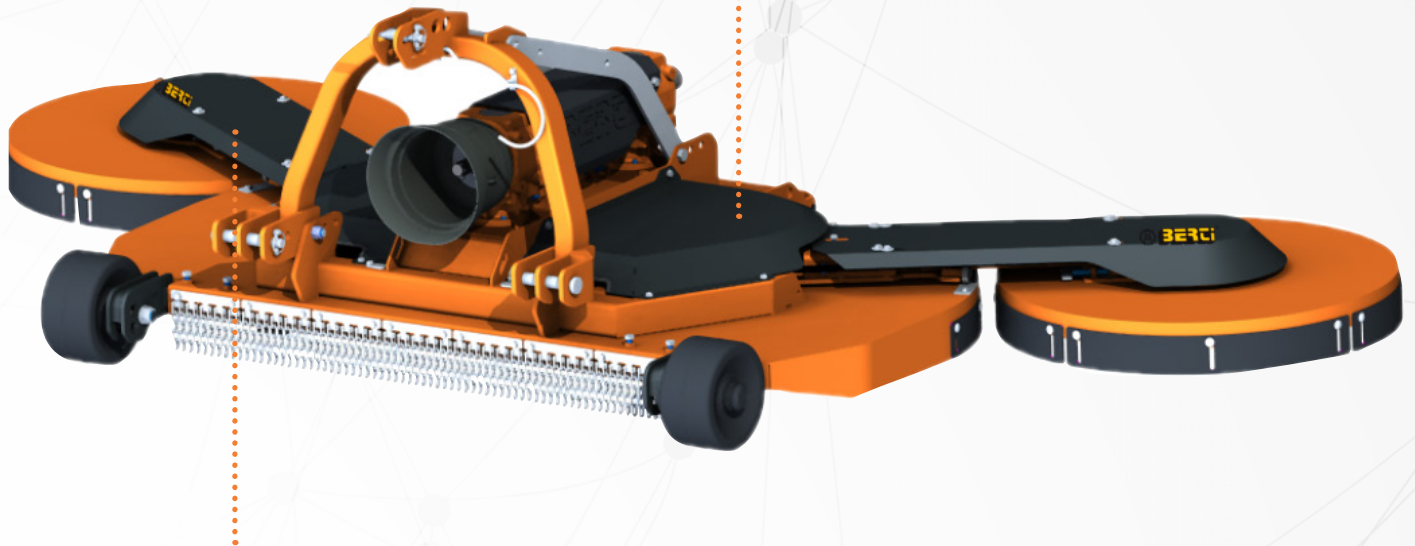

SECONDARY TRANSMISSION

High power belts





DOUBLE GEARBOX

The use of double gearbox allows the mower to reduce consumption and limits noise.

RUBBER FLEX COUPLING

Reduces torque peaks by protecting gearboxes

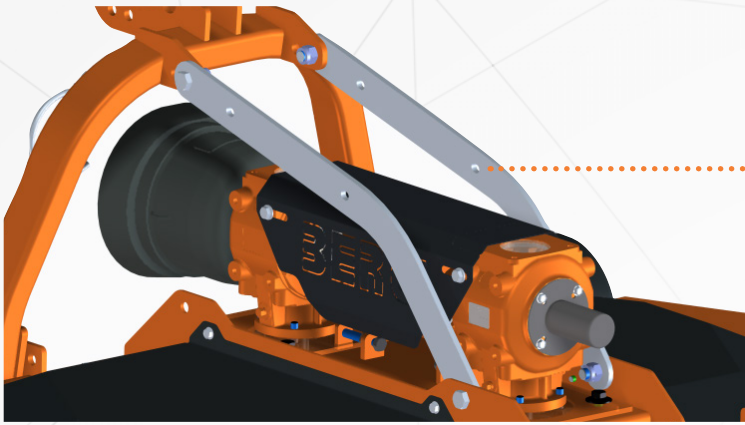
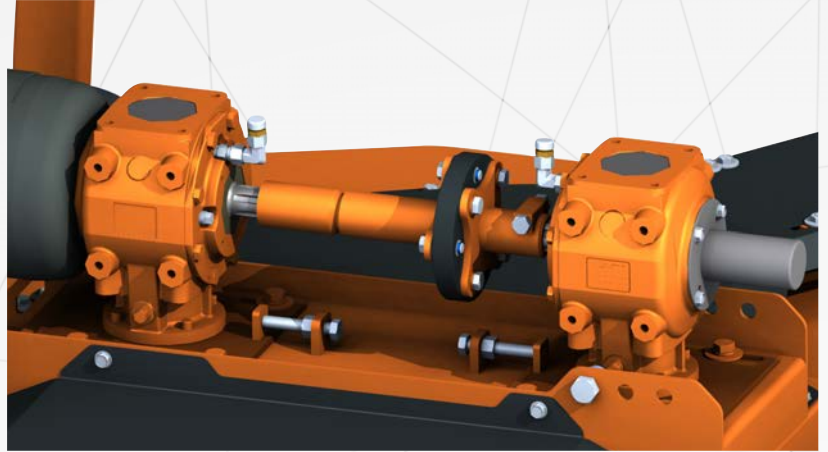

DOUBLE TIE ROD

It ensures better weight distribution during transport and manoeuvring.

HYDRAULICALLY OPENING DISCS

Available in different sizes:
60-70-80-90

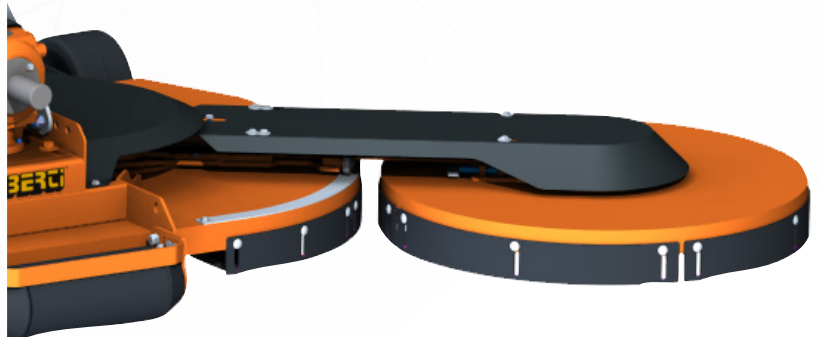

ELECTRO-HYDRAULIC FEELERS

VARIANT electro-hydraulic feelers allow inter-row shredding on both rows simultaneously. This function allows complete processing in a single pass, optimizing times and reducing costs.

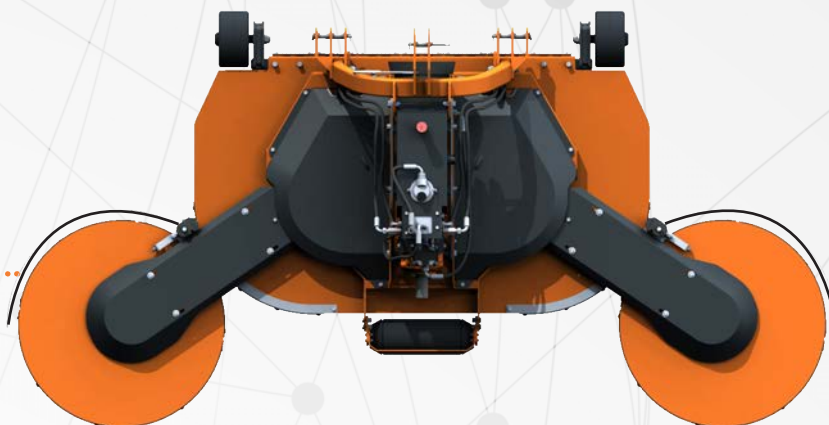

ELECTRO-HYDRAULIC FEELER

Sensitive, precise and fast.



INDEPENDENT OIL TANK

With the electro-hydraulic feeler option



WHEELS AND ROLLER

FRONT METAL-TYPE WHEELS (standard)

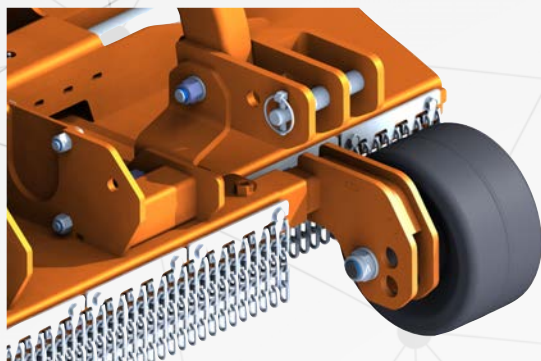

REAR ROLLER (standard)



FRONT RUBBER-TYPE WHEELS (standard)

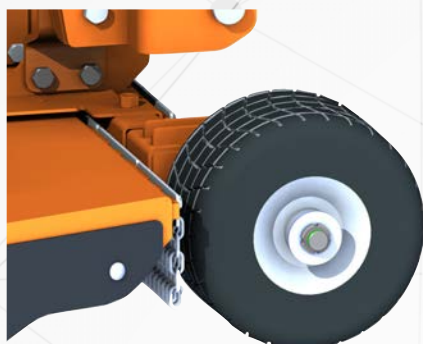



ADDITIONAL APPLICATIONS

EUROSTAR - B-FLEX

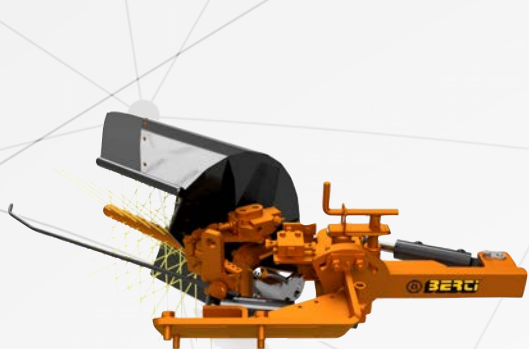

WEEDER - SINGLE

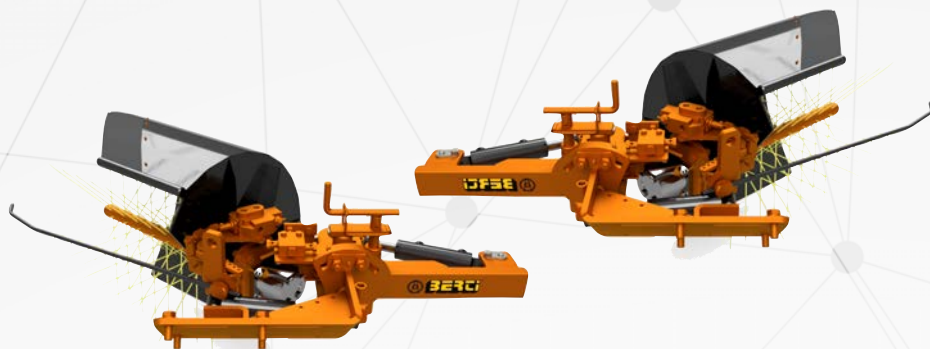

WEEDER - DOUBLE



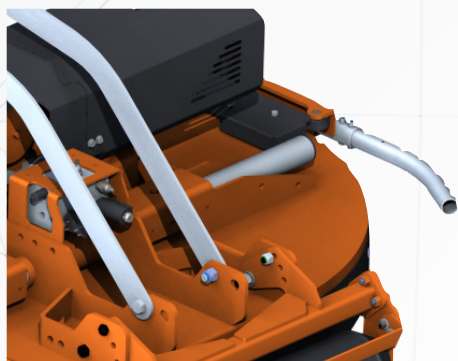







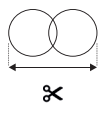
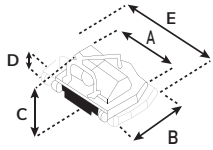

B-FLEX













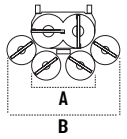
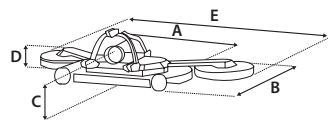







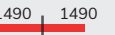

ELECTRO-HYDRAULIC FEELER BOTH SIDES

Allows the machine to automatically adapt
to the width of the rows.

TECHNICAL DATA

MOD.													
	cm	A (cm)	B (cm)	C (cm)	D (cm)	mm *	min	max	n°	n°	PTO	min	max
EUROSTAR 160	158	162	140	94	18		30	80	4	4	540 (1000)	390	490
EUROSTAR 180	178	182	146	94	18		30	80	4	4	540 (1000)	420	515
EUROSTAR 200	198	202	156	94	18		40	80	4	4	540 (1000)	470	560
EUROSTAR 220	218	222	161	94	18		40	80	4	4	540 (1000)	490	590
EUROSTAR 240	238	242	168	94	18		40	80	4	4	540 (1000)	520	620

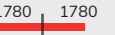
* version with lateral displacement, +/- 200 mm

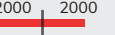
MOD.															
	A (cm)	B (cm)	A (cm)	B (cm)	C (cm)	D (cm)	E (cm)	mm	min	max	n°	n°	PTO	min	max
VARIANT 160-260 Ø 60	158	266	162	188	87	24	272		30	80	8	4	540 (1000)	520	620
VARIANT 160-260 Ø 70	158	284	166	196	87	24	290		30	80	8	4	540 (1000)	530	630
VARIANT 180-280 Ø 60	178	280	182	190	87	24	284		40	80	8	4	540 (1000)	550	650
VARIANT 180-300 Ø 70	178	298	182	201	87	24	304		40	80	8	4	540 (1000)	560	660
VARIANT 180-320 Ø 80	178	315	182	211	87	24	325		40	80	8	4	540 (1000)	570	670
VARIANT 200-300 Ø 60	198	300	202	201	87	24	306		50	80	8	4	540 (1000)	590	690
VARIANT 200-320 Ø 70	198	318	202	210	87	24	324		50	80	8	4	540 (1000)	600	700
VARIANT 200-340 Ø 80	198	343	202	224	87	24	348		50	80	8	4	540 (1000)	610	710
VARIANT 200-360 Ø 90	198	352	209	229	87	24	359		50	80	8	4	540 (1000)	620	720
VARIANT 220-320 Ø 60	218	321	220	211	87	24	327		50	80	8	4	540 (1000)	630	730
VARIANT 220-340 Ø 70	218	341	220	222	87	24	347		50	80	8	4	540 (1000)	640	740
VARIANT 220-360 Ø 80	218	356	220	230	87	24	362		50	80	8	4	540 (1000)	650	750
VARIANT 220-380 Ø 90	226	375	232	240	87	24	381		50	80	8	4	540 (1000)	660	760
VARIANT 240-400 Ø 90	238	399	247	250	87	24	405		60	120	8	4	540 (1000)	680	780

TECHNICAL DATA

MOD.														
	min	max	A (cm)	B (cm)	C (cm)	D (cm)	E (cm)	mm *	min	max	n°	n°	PTO	kg
B/FLEX 120-150	119	147	124	129	980	24	152		40	100	2	4	540 (1000)	470
B/FLEX 140-195	142	190	146	146	980	24	194		40	100	2	4	540 (1000)	530
B/FLEX 175-245	175	240	179	165	980	24	244		40	100	2	4	540 (1000)	607
B/FLEX 190-260	192	257	196	180	980	24	261		40	100	2	4	540 (1000)	715
B/FLEX 220-300	220	300	224	200	980	24	304		40	100	2	4	540 (1000)	850

* version with lateral displacement, +/- 200+200 mm

MOD.															
	A (cm)	B (cm)	A (cm)	B (cm)	C (cm)	D (cm)	E (cm)	mm	min	max	n°	n°	PTO	min	max
AV 180-230 Ø 65	176	230	185	240	57	28	190		30	80	4	8	540 (1000)	595	-
AV 180-245 Ø 80	192	243	202	255	57	28	198		30	80	4	8	540 (1000)	605	-
AV 200-250 Ø 65	200	252	207	261	57	28	199		40	90	4	8	540 (1000)	620	-
AV 200-265 Ø 80	200	266	210	277	57	28	215		40	90	4	8	540 (1000)	630	-
AV 235-290 Ø 65	235	287	243	296	57	28	213		40	90	4	8	540 (1000)	680	-
AV 235-300 Ø 80	240	299	251	310	57	28	229		50	90	4	8	540 (1000)	690	-
AV 260-320 Ø 65	264	317	268	324	57	28	199		50	90	5	10	540 (1000)	700	-
AV 260-335 Ø 80	264	331	273	340	57	28	215		50	90	5	10	540 (1000)	710	-
AV 310-360 Ø 65	312	366	316	372	57	28	213		50	90	5	10	540 (1000)	760	-
AV 310-375 Ø 80	316	376	326	385	57	28	229		50	90	5	10	540 (1000)	770	-

NOTES

A series of horizontal dotted lines for writing notes, overlaid on a background of a network diagram with nodes and connecting lines.



BERTI MACCHINE AGRICOLE SPA

Via Musi 1/A-3-4

37042 Caldiero (Verona) - Italy

+39 045 61 39 711

bertima.it

info@bertima.it

follow us:

